

# TFMOV

Thermally Protected Varistors-Mechanical trip

TFMOV20M Series

## Description



Thermally Protected Varistors - Mechanically Off Type Thermally Protected Varistors (TFMOV) are thermally protected varistors. TFMOVs have all the characteristics of a varistor (MOV) with the added benefit of thermal protection. MOVs are subject to two types of deterioration: natural deterioration due to prolonged operation, and deterioration due to abnormal surges. When a surge occurs, the leakage current of the degraded MOV increases continuously, causing the surface temperature of the MOV to rise continuously and the possibility of fire. At this time, the heat of the MOV in TFMOV is conducted to the cryogenic alloy solder joint, which senses the abnormal temperature and operates (fuses), driving the spring slider to cut off the circuit, disconnecting the MOV from the main circuit and thus protecting the entire circuit, as well as the MOV itself will not continue to heat up, and the phenomenon of catching fire.

SETfuse (SETsafe | SETfuse) thermally protected varistor-mechanical release type TFMOV10M series is mainly composed of varistor (MOV), mechanical release device, flame-retardant housing and metal components (pins, springs). Nominal Discharge Current: 20 kA; Maximum Continuous Operating Voltage: (50 ~ 750) VAC; Maximum Continuous Operating DC Voltage: (500 ~ 1000) VDC Safety Certification: UL, cUL, TUV, CE; RoHS, REACH compliant.

## Schematics

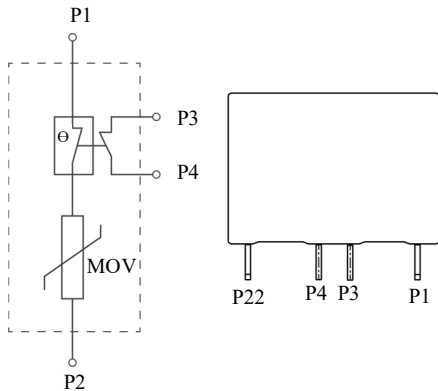

TFMOV (Mechanical trip)

## Structure

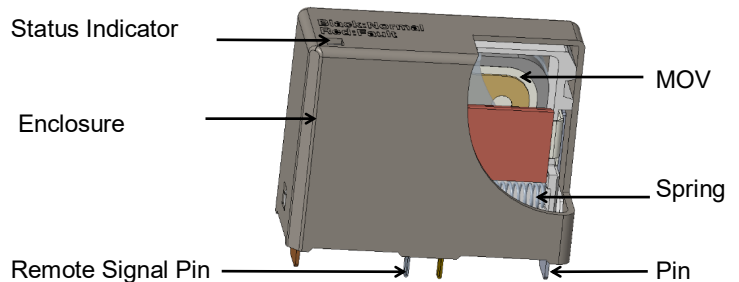

TFMOV (Mechanical trip)





## Features

- Overvoltage Protection has High Breaking Capacity and Fast Trip Response
- It Can Meet the Working Temperature of -40 ~ 105 °C
- Thermal Protection, High Reliability
- Small Size
- Remote Signal Contact for Failure Indication
- High Energy Capacity
- Sealing Material, Flame-retardant to V0 (UL 94)
- Comply with UL 1449 / IEC 61643-11

## Applications

- Telecom Equipment
- String Inverter in Photovoltaic System
- AC / DC Power Supply
- Uninterruptable Power Supply (UPS)
- Surge Protective Device (SPD)
- Electric Meter
- Power Distribution Unit (PDU)
- Lightning Protection Socket

### Agency Approvals

Agency Symbol	Standards	The File No. and certification No. obtained by SETsafe   SETfuse	Category
	UL 1449 4th	E322662	Type 4CA Type 1CA
	CSA C22. 2 NO. 5 CSA C22. 2 NO. 4	E322662	Type 4CA Type 1CA
	EN 61643-11, EN 61643-31	R 50603926	Class II and Class III
	IEC/EN 61643-11, IEC/EN 61643-31	AN 50603238	Class II and Class III
Environment	RoHS & REACH	Compliant	

### Part Numbering System

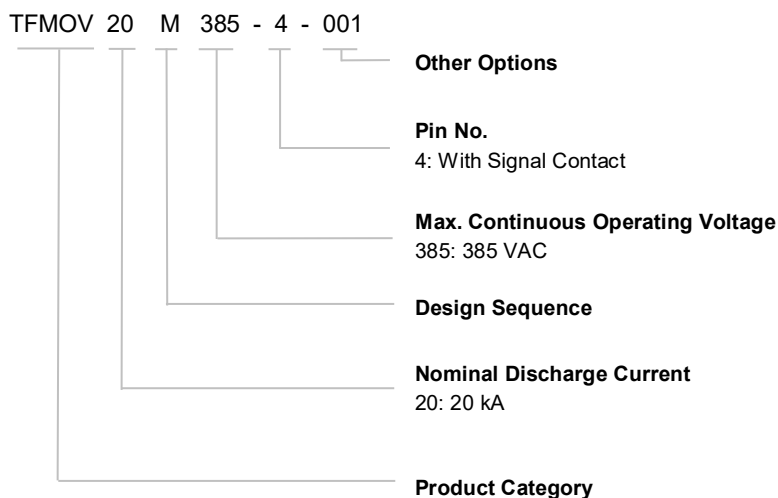

**Reminder:**

1. Pin number and other options are used only as identification codes for internal unique specifications and are not part of the product model
2. Part numbering system in the datasheet is only for selecting correct parameter and product features. Before placing order, please contact us for specifications and use the part number and product code in the specifications to place order to ensure the part is correct. Product code is the unique identification.

# TFMOV

Thermally Protected Varistors-Mechanical trip

TFMOV20M Series

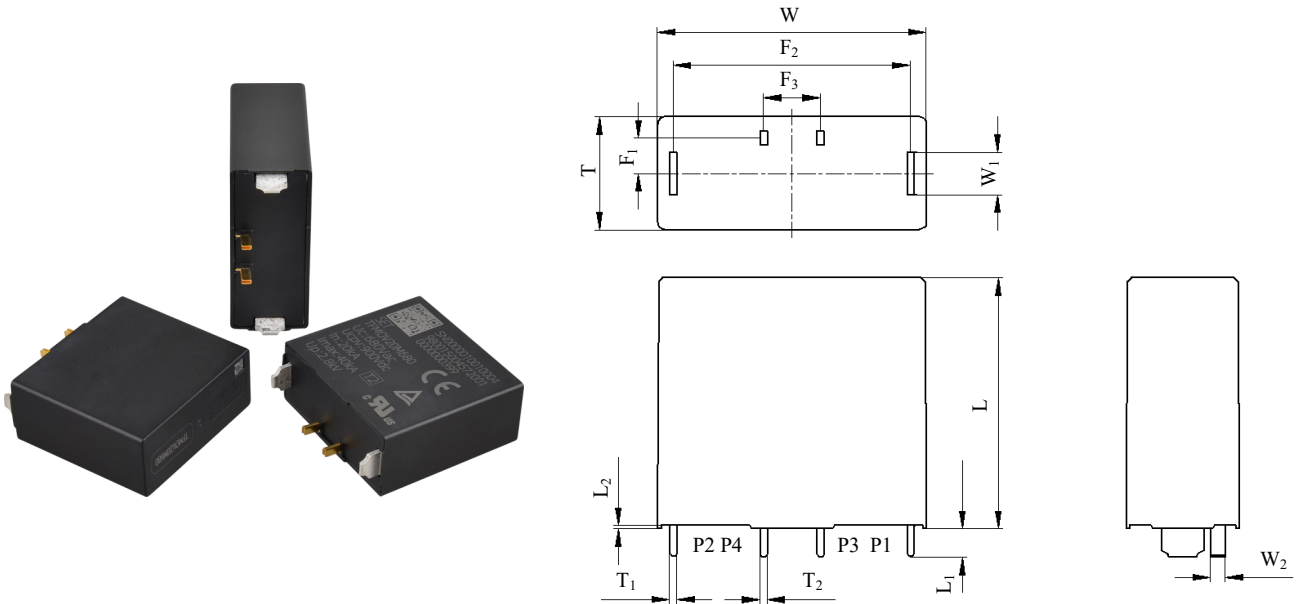

Note: Unit: mm

L	L <sub>1</sub>	L <sub>2</sub>	W	W <sub>1</sub>	W <sub>2</sub>
35.5 ± 1.0	4.0 ± 0.5	0.5 ± 0.3	38.0 ± 1.0	6.0 ± 0.5	2.0 ± 0.3
T	T <sub>1</sub>	T <sub>2</sub>	F <sub>1</sub>	F <sub>2</sub>	F <sub>3</sub>
16.0 ± 1.0	1.0 ± 0.2	1.0 ± 0.2	5.0 ± 0.5	33.5 ± 0.5	8.0 ± 0.5

# TFMOV

Thermally Protected Varistors-Mechanical trip

## TFMOV20M Series

### Specifications

Model	Nominal System Voltage	Nominal Varistor Voltage @1mA	Max. Continuous Operating Voltage		Nominal Discharge Current (8/20 μs)	Max. Discharge Current(8/20 μs)	Voltage Protection Level	SCCR	UL1449			IEC/ EN 61643-11	IEC/ EN 61643-31
	$U_n$	$V_N$	MCOV		$I_n$	$I_{max}$	$U_p$		AC Type 1CA	DC Type 4CA	Class II	Class II	
	(VAC)	(V)	$U_c$ (VAC)	$U_{cpv}$ (VDC)	(kA)	(kA)	(V)	(kA)					
TFMOV20M50	24	82	50	-	20	40	400	-	○	●	○	●	○
TFMOV20M60	48	100	60	-	20	40	450	-	○	●	○	●	○
TFMOV20M75	60	120	75	-	20	40	450	-	○	●	○	●	○
TFMOV20M95	60	150	95	-	20	40	500	-	○	●	○	●	○
TFMOV20M115	108	180	115	-	20	40	500	-	○	●	○	●	○
TFMOV20M130	120	200	130	-	20	40	600	-	○	●	○	●	○
TFMOV20M140	120	220	140	-	20	40	600	-	○	●	○	●	○
TFMOV20M150	120	240	150	-	20	40	700	-	○	●	○	●	○
TFMOV20M175	120	270	175	-	20	40	700	200	●	●	○	●	○
TFMOV20M190	120	300	190	-	20	40	750	-	○	●	○	●	○
TFMOV20M210	120	330	210	-	20	40	800	-	○	●	○	●	○
TFMOV20M230	120	360	230	-	20	40	900	-	○	●	○	●	○
TFMOV20M250	220	390	250	-	20	40	1000	-	○	●	○	●	○
TFMOV20M275	230	430	275	-	20	40	1100	-	○	●	○	●	○
TFMOV20M300	230	470	300	-	20	40	1200	200	●	●	○	●	○
TFMOV20M320	277	510	320	-	20	40	1300	-	○	●	○	●	○
TFMOV20M350	277	560	350	-	20	40	1500	200	●	●	○	●	○
TFMOV20M385	277	620	385	500	20	40	1800	-	○	●	●	●	●
TFMOV20M420	347	680	420	560	20	40	1800	200	●	●	●	●	●
TFMOV20M460	347	750	460	600	20	40	2000	-	○	●	●	●	●
TFMOV20M510	347	820	510	670	20	40	2000	-	○	●	●	●	●
TFMOV20M550	480	910	550	720	20	40	2500	200	●	●	●	●	●
TFMOV20M625	480	1000	625	800	20	40	2500	-	○	●	●	●	●
TFMOV20M680	480	1100	680	900	20	40	2800	-	○	●	●	●	●
TFMOV20M750	480	1200	750	1000	20	40	3300	-	○	●	●	●	●

Note:

1.The Value of Voltage Protection Level ( $U_p$ ) is determined according to IEC 61643-11:2011 clause 6.4.

Preferred values of voltage protection level (kV): 0.08, 0.09, 0.10, 0.12, 0.15, 0.22, 0.33, 0.4, 0.5, 0.6, 0.7, 0.8, 0.9, 1.0, 1.2, 1.5, 1.8, 2.0, 2.5, 3.0, 4.0, 5.0, 6.0, 8.0, 10.

2."●" indicates that the product has been certified, "○" indicates that the product is not certified.

### Performance Curve for Reference

Limited Current Test Curve (UL 1449 clause 44.4)

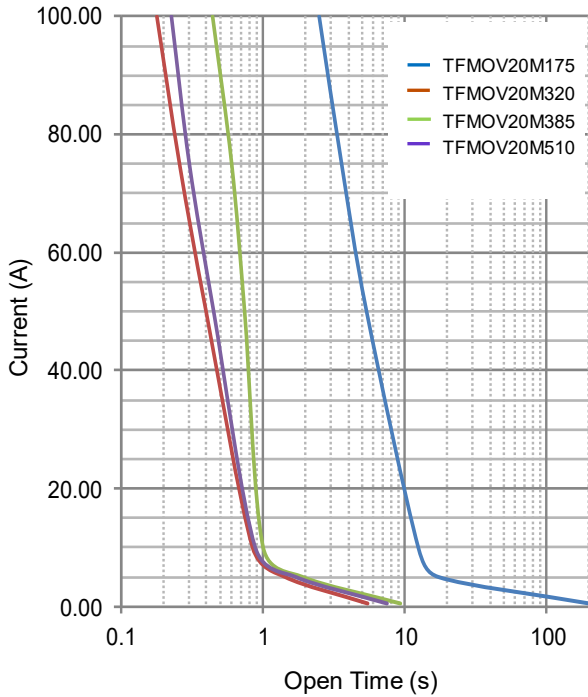

Note:  
The limited current test curve is for reference only.

Max. Peak Current Derating Curve

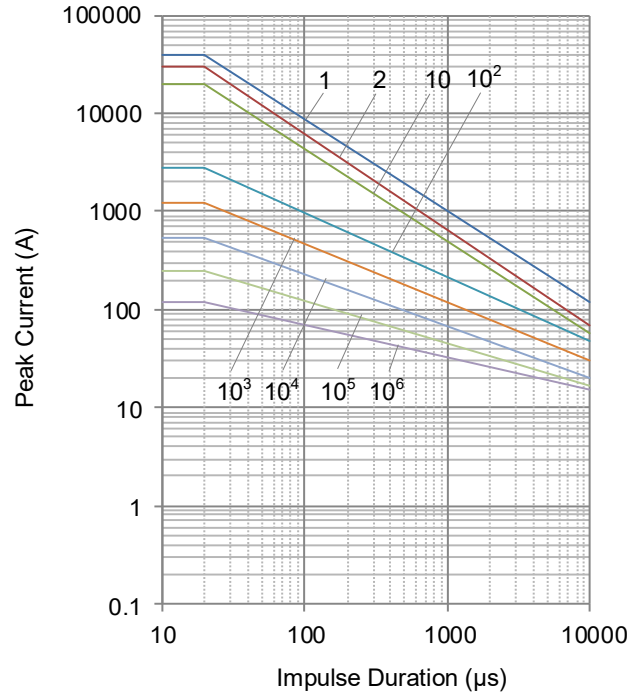

Note:  
1, 2, 10, 10<sup>2</sup>, 10<sup>3</sup>, 10<sup>4</sup>, 10<sup>5</sup>, 10<sup>6</sup> Stand for number of repetitions.

### Voltage-Current Characteristic Curves

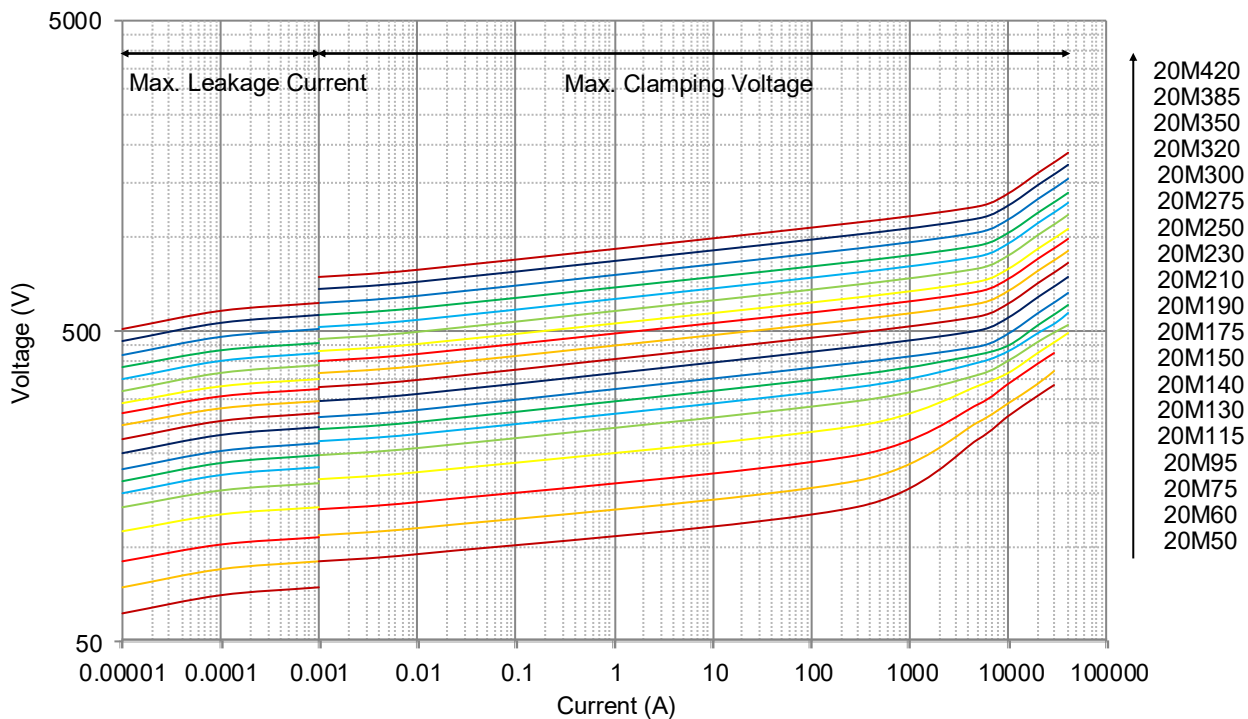

# TFMOV

Thermally Protected Varistors-Mechanical trip

TFMOV20M Series

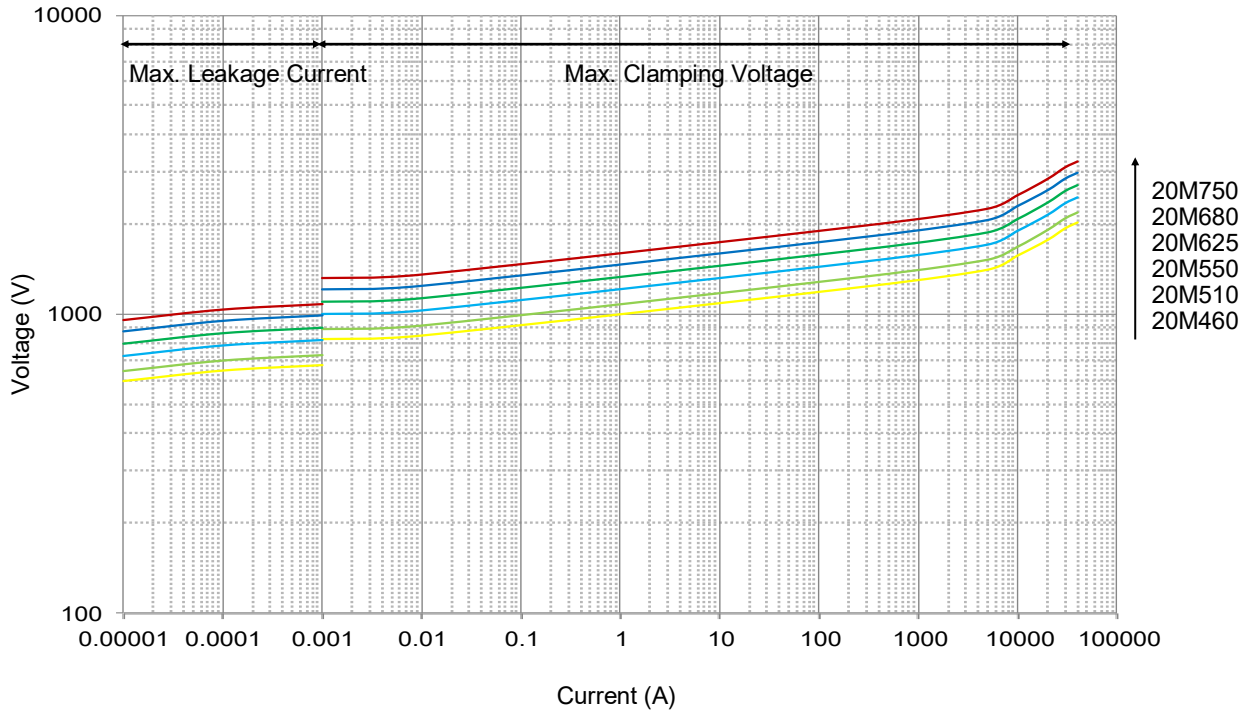

## Packaging Information

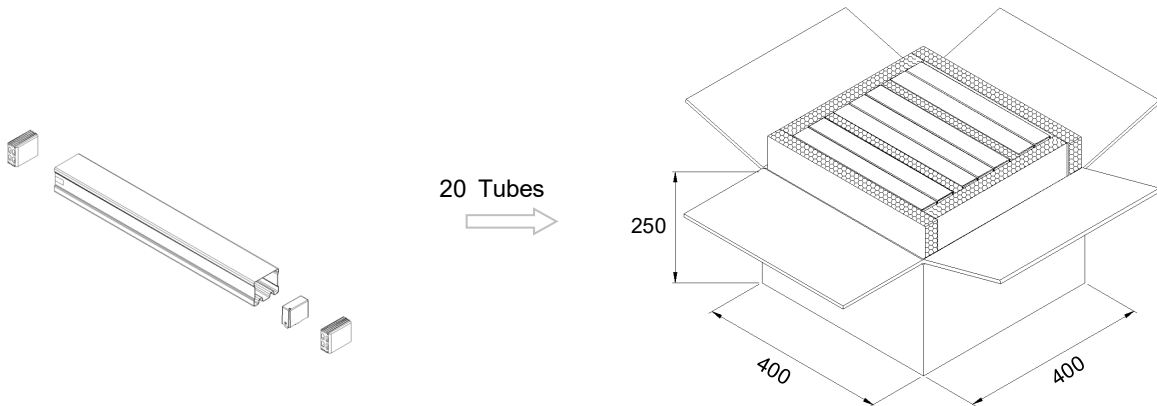

Unit: mm;  
Please contact us if you have special packaging requirements.

Item	Tube	Carton
Dimensions (mm)	46 × 43 × 318	400 × 400 × 250
Quantity (PCS)	17	340

**Wave Soldering Parameters (Reference)**

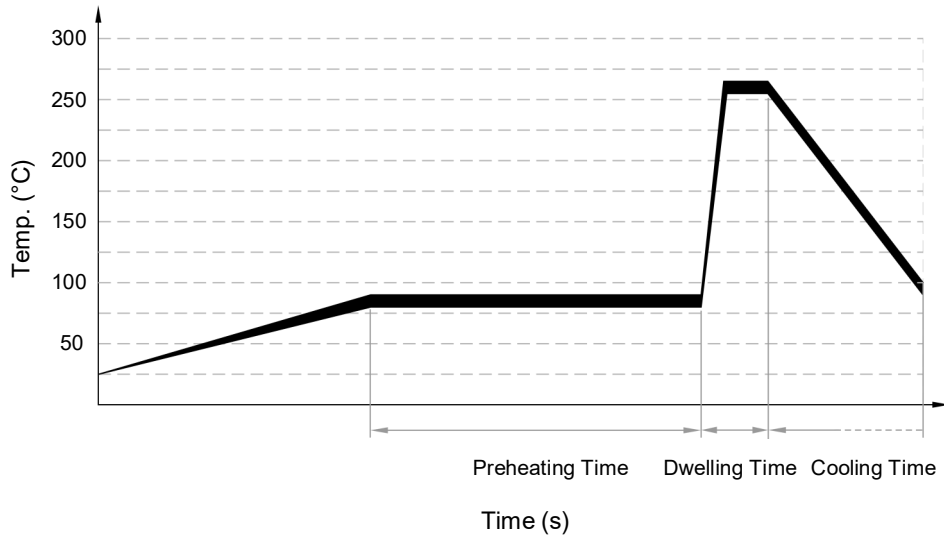

Item	Temp. (°C)	Time (s)
Preheating	80 ~ 120	60 ~ 150
Dwelling	250 ~ 270	4 ~ 6

**Recommended Hand-Soldering Parameters**

Item	Condition
Iron Temperature	350 °C (Max.)
Soldering Time	4 seconds (Max.)
Distance between Soldering Point and the Bottom of Product	2 mm (Min.)

### MOV Operation Principle

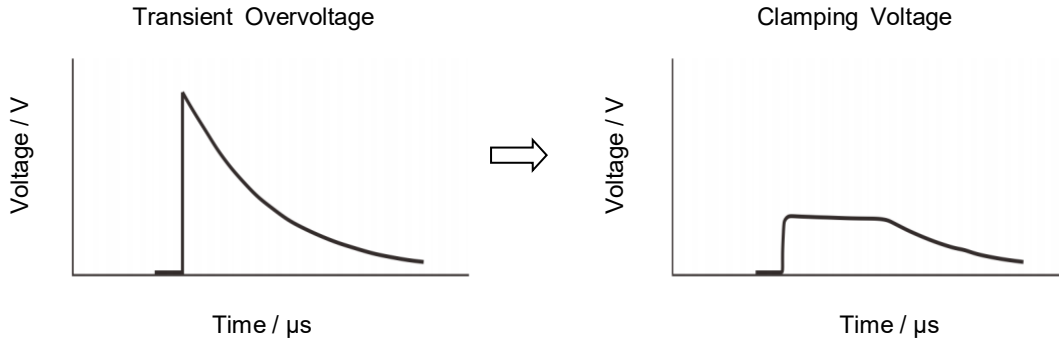

### Thermal Protection MOV

Figure a is a surge protection circuit commonly used in power supplies. MOV is used to suppress the surge voltage and protect the subsequent circuit. There is a risk of burning when the varistor degrades or fails. In the high-reliability surge protection circuit of Figure b, in order to improve the safety of the circuit, a thermal protection varistor TFMOV is used as the surge voltage protection element. TFMOV is a combination of varistors (MOV) and thermal protection component. When the temperature of the MOV is abnormally exceeded, the thermal fuse will be opened first, so that the failure mode of the MOV appears to be open-circuit failure.

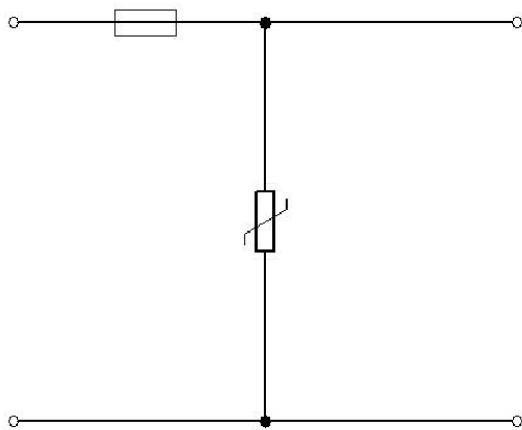

Figure a Typical surge protection circuit

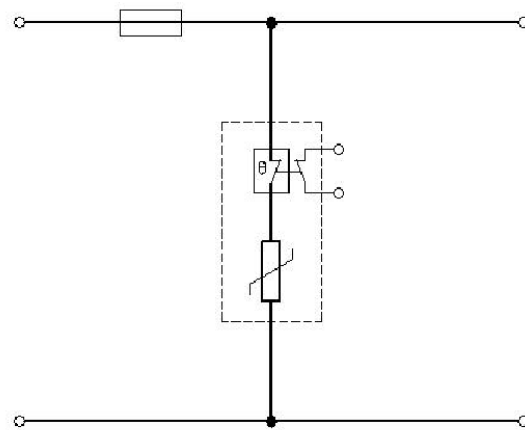

Figure b: High reliability surge protection circuit



# TFMOV

Thermally Protected Varistors-Mechanical trip

TFMOV20M Series

## Benefits

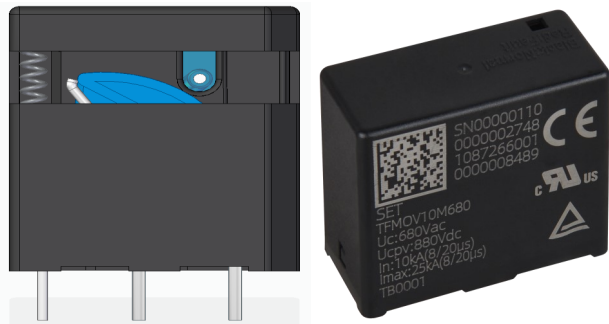

### TFMOV Failure Simulation

During the electrical performance degrading of varistor, the inbuilt ATCO will open the circuit when the leakage current of varistor increases to tens of micro Amperes. As shown in the figure above, this is a safe open circuit failure.

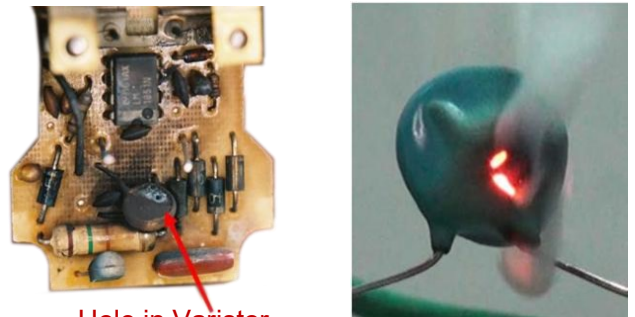

Hole in Varistor

### MOV Failure Simulation

The electrical performance of varistor degrades with operating, mostly the varistor voltage drops, and leakage current increases. The heat accumulation can cause the temperature increase sharply and varistor results in thermal breakdown to short circuit status. It's very dangerous.

# TFMOV

Thermally Protected Varistors-Mechanical trip

TFMOV20M Series

## Application Options

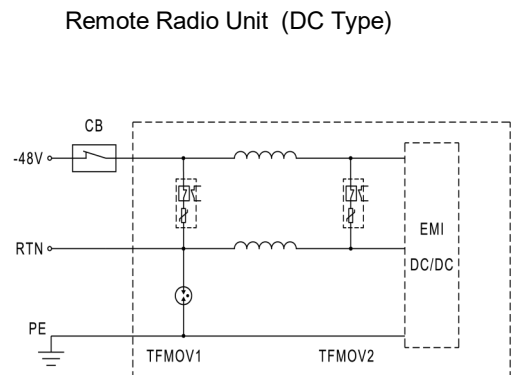
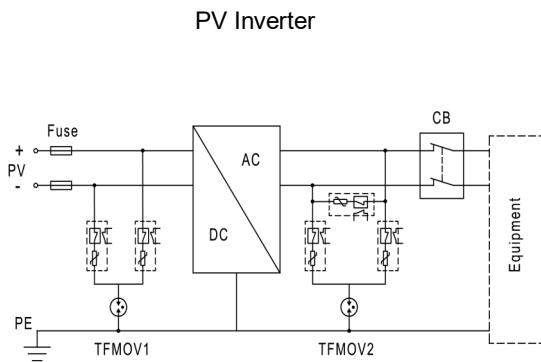
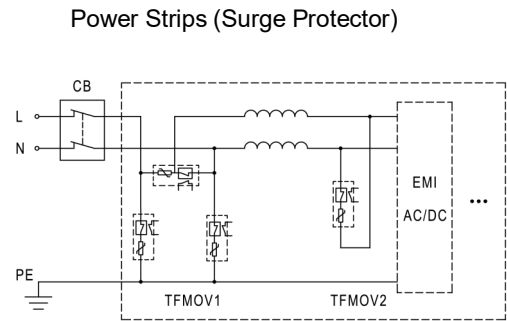
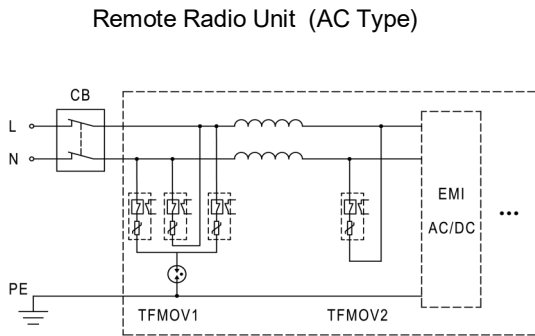

## Design

When a single TFMOV surge capacity can't meet the requirement of customers, paralleling more TFMOVs is recommended. Due to its nonlinear current-voltage characteristics, please pay attention to below tips:

1. Use the TFMOV from the same manufacturer with same model to parallel.
2. Control the varistor voltage; Typically, the varistor voltage deviation should be less than 1% in the same group (between the Max and Min), and meet the next tip at the same time.
3. Calculate the average surge capacity for each TFMOV and keep a margin at least 10%.
4. Design the layout like Figure.2. to make sure the surge capacity is divided averagely.

The Design not Recommended

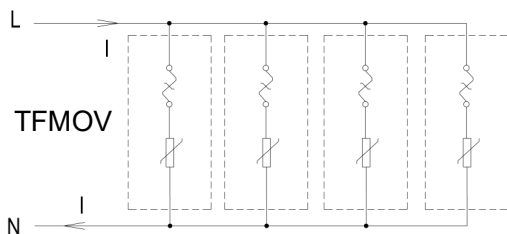

Figure .1

The Design Recommended

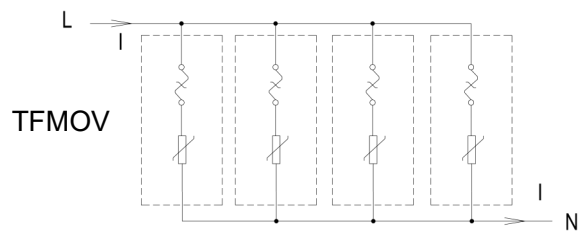

Figure .2

Glossary

Item	Description
$V_N$	<b>Nominal Varistor Voltage</b> Voltage, at specified d.c. current used as a reference point in the component characteristic. — (IEC 61643-11)
8/20 $\mu$ s	<b>8/20 Current Impulse</b> Current impulse with a nominal virtual front time of 8 $\mu$ s and a nominal time to half-value of 20 $\mu$ s. — (IEC 61643-11)
1.2/50 $\mu$ s	<b>1.2/50 Voltage Impulse</b> Voltage impulse with a nominal virtual front time of 1.2 $\mu$ s and a nominal time to half-value of 50 $\mu$ s. — (IEC 61643-11)
$U_c$	<b>Maximum Continuous Operating Voltage</b> Maximum r.m.s. voltage, which may be continuously applied to the SPD's mode of protection. — (IEC 61643-11)
$I_n$	<b>Nominal Discharge Current</b> Crest value of the current through the SPD having a current waveshape of 8/20. — (IEC 61643-11)
$I_{imp}$	<b>Impulse Discharge Current for Class I Test</b> Crest value of a discharge current through the SPD with specified charge transfer Q and specified energy W/R in the specified time. — (IEC 61643-11)
$I_{max}$	<b>Maximum Discharge Current</b> Crest value of a current through the SPD having an 8/20 waveshape and magnitude according to the manufacturers specification. $I_{max}$ is equal to or greater than $I_n$ . — (IEC 61643-11)
$V_c$	<b>Clamping Voltage</b> Peak voltage developed across the varistor terminations under standard atmospheric conditions, when passing an 8/20 $\mu$ s class current pulse. — (IEC 61643-11)
$C_v$	<b>Capacitance</b> Capacitance across the MOV measured at a specified frequency and voltage. — (IEC 61643-11)
<b>Modes of protection</b>	<b>Mode of protection of an SPD</b> An intended current path, between terminals that contains protective components, e.g. line-to-line, line-to-earth, line-to-neutral, neutral-to-earth. — (IEC 61643-11)
$U_p$	<b>Voltage Protection Level</b> Maximum voltage to be expected at the SPD terminals due to an impulse stress with defined voltage steepness and an impulse stress with a discharge current with given amplitude and waveshape. — (IEC 61643-11)
IP	<b>Degree of protection of enclosure</b> Classification preceded by the symbol IP indicating the extent of protection provided by an enclosure against access to hazardous parts, against ingress of solid foreign objects and possibly harmful ingress of water — (IEC 61643-11)
MOV	<b>Varistors</b> A resistive device with nonlinear voltammetry characteristics — (IEC 61643-11)

## Patents

Name	Region	Category	Patent NO.
Varistor with In-built Alloy-Type Thermal Fuse	China	Patent for Invention	ZL 200510044661.5
A Protection Pluggable Module with Over Current、 Over Voltage、 and Over Temperature Protection Function	China	Utility Model	ZL 201020244488.X
A Varistor with Double Protection Function	China	Utility Model	ZL 201020255481.8
Surge Protection Module Applicable for Power Strip	China	Utility Model	ZL 201120107173.5
A Surge Protection Module Applicable for Power Strip	China	Patent for Invention	ZL 201110092261.7
A New Type of Varistor and Surge Protective Device with Thermal Protection	China	Utility Mode	ZL 201420306127.1
A Surge Protective Device	China	Utility Modeel	ZL 201420415059.2
A Varistor and Thermal Protection Component Combination	China	Utility Mode	ZL 201520376567.9
合金型温度ヒューズ付のバリスタ	Japan	Utility Mode	3142835
Varistor with an Alloy-Type Temperature Fuse	Australia	Utility Mode	2007100456
Varistor with an Alloy-Type Temperature Fuse	Taiwan	Utility Model	M 300855
Varistor with an Alloy-type Temperature Fuse	Canada	Patent for Invention	2588819
Metal Oxide Varistor with Built-in Alloy-Type Temperature Fuse	USA	Patent for Invention	US 8780521
Varistor with In-built Alloy Type Thermal Fuse (with Housing)	USA	Patent for Invention	US 9355763



## ATTENTION

### Usage

1. The voltage applied continuously to the TFMOV can not exceed its maximum continuous operating voltage  $U_c$ .
2. When atmosphere press is from 45 kPa to 106 kPa, the related altitude shall be from 5000 meters to - 500 meters.
3. Do not touch the product body or pins directly when power is on, to avoid electric shock.
4. Do not clean the TFMOV with strong polar solvent such as ketone, esters, benzene, halogenated hydrocarbon, to avoid damaging the enclosure.
6. It should have a reliable grounding when using these products.

### Replacement

TFMOV is a non-repairable product. For safety sake, please use equivalent TFMOV for replacement.

### Storage

Do not store TFMOV at high temperature, high humidity or corrosive gas environment. To avoid reducing the solderability of the pins, please use them up within 1 year after receiving the goods.

### Installation Position

Do not install the TFMOV on a place that may often suffer severe continuous vibration.

### Mechanical Stress

Do not take violent action such as knocking when assembling to avoid mechanical damage.

**Thermal Fuse & MOV (TFMOV) Feature & Model List Overview**

Rated Voltage $U_n$ (V)		Nominal Discharge Current $I_n$ (kA)				Page		Model	Maximum Continuous Operating Voltage $U_n$ (V)
		5	10	20	20	AC	DC		
690V	600V			TFMOV20M750		750	750		
		TFMOV05M750							
480V	400V	TFMOV05M680	TFMOV10M680	TFMOV20M680	TFMOV25M680TI	680	680		
		TFMOV05M625	TFMOV10M625	TFMOV20M625	TFMOV25M625TI	625	625		
					TFMOV25M575TI	575	575		
347V	300V	TFMOV05M550	TFMOV10M550	TFMOV20M550	TFMOV25M550TI	550	550		
		TFMOV05M510	TFMOV10M510	TFMOV20M510	TFMOV25M510TI	510	510		
		TFMOV05M460	TFMOV10M460	TFMOV20M460		460	460		
254 - 220 - 230V	220V				TFMOV25M440TI	440	440		
		TFMOV05M420	TFMOV10M420	TFMOV20M420		420	420		
		TFMOV05M385	TFMOV10M385	TFMOV20M385	TFMOV25M385TI	385	385		
220 - 230V	300V	TFMOV05M350	TFMOV10M350	TFMOV20M350		350	350		
		TFMOV05M320	TFMOV10M320	TFMOV20M320		320	320		
		TFMOV05M300	TFMOV10M300	TFMOV20M300		300	300		
120 - 130V	220V	TFMOV05M275	TFMOV10M275	TFMOV20M275		275	275		
		TFMOV05M250	TFMOV10M250	TFMOV20M250		250	250		
		TFMOV05M230	TFMOV10M230	TFMOV20M230		230	230		
110V	110V	TFMOV05M210	TFMOV10M210	TFMOV20M210		210	210		
		TFMOV05M190	TFMOV10M190	TFMOV20M190		190	190		
		TFMOV05M175	TFMOV10M175	TFMOV20M175		175	175		
60V	60V	TFMOV05M150	TFMOV10M150	TFMOV20M150		150	150		
		TFMOV05M140	TFMOV10M140	TFMOV20M140		140	140		
		TFMOV05M130	TFMOV10M130	TFMOV20M130		130	130		
48V	48V	TFMOV05M115	TFMOV10M115	TFMOV20M115		115	115		
		TFMOV05M95	TFMOV10M95	TFMOV20M95		95	95		
		TFMOV05M75	TFMOV10M75	TFMOV20M75		75	75		
36V	36V	TFMOV05M60	TFMOV10M60	TFMOV20M60		60	60		
		TFMOV05M50	TFMOV10M50	TFMOV20M50		50	50		
						40	40		
24V	24V					35	35		
						30	30		
						25	25		
12V	12V								